

SERVICE INSTRUCTION

RUNNING MODIFICATIONS ON

ROTAX® ENGINE TYPE 912/914 (SERIES)

SI-912-020 R4

SI-914-022 R4

Symbols used:

Please, pay attention to the following symbols throughout the Service Bulletin emphasizing particular information.

▲ **WARNING:** Identifies an instruction, which if not followed, may cause serious injury or even death.

■ **CAUTION:** Denotes an instruction which if not followed, may severely damage the engine or could lead to suspension of warranty.

◆ **NOTE:** Information useful for better handling.

|| | A revision bar outside of the page margin indicates a change to text or graphic.

1) Planning information

1.1) Engines affected

All versions of the engine type:

- 912 Series all - 912 pre-series engines all
- 914 Series all - 914 pre-series engines all

1.2) Concurrent ASB/SB/SI and SL

none

1.3) Reason

ROTAX® reserves the right to abandon or modify specifications, design, details, models or equipment at any time without obligation.

1.4) Subject

Running modifications on ROTAX® engine type 912/914 (Series).

1.5) Compliance

NONE - For Information Only

▲ **WARNING:** Non-compliance with these instructions could result in engine damage, personal injury or death!

1.6) Approval

The technical content is approved under the authority of DOA Nr. EASA.21J.048.

1.7) References

In addition to this technical information refer to

- current issue of the Operators Manual (OM)
- engine data sheet
- power, torque and fuel consumption curves
- current issue of the Illustrated Parts Catalog (IPC)
- Installation Manual (IM)
- all relevant Alert Service Bulletins (ASB)
- all relevant Service Bulletins (SB)
- all relevant Service Instructions (SI)
- all relevant Service Letters (SL)
- Maintenance Manual (MM)
- Users Guide

◆ **NOTE:** The status of Manuals can be determined by checking the table of amendments of the Manual. The 1st column of this table is the revision status. Compare this number to that listed on the ROTAX WebSite: www.rotax-aircraft-engines.com. Updates and current revisions can be downloaded for free.

cd04936

2) Material Information

2.1) Material - cost and availability

Price and availability will be supplied on request by ROTAX[®] Authorized Distributors or their Service Center.

2.2) Special tooling/lubricant-/adhesives-/sealing compound -

Price and availability will be supplied on request by ROTAX[®] Authorized Distributors or their Service Center.

3) Accomplishment / Instructions

All the measures must be taken and confirmed by the following persons or facilities:

- ROTAX[®] -Distributors or their Service Center
- Persons with the respective Aviation Authority

▲ **WARNING:** Proceed with this work only in a non-smoking area and not close to sparks or open flames. Switch off ignition and secure engine against unintentional operation. Secure aircraft against unauthorized operation. Disconnect negative terminal of aircraft battery.

▲ **WARNING:** Risk of scalds and burns! Allow engine to cool sufficiently and use appropriate safety gear while performing work.

▲ **WARNING:** Should removal of a locking device (namely lock tabs, self-locking fasteners) be required when undergoing disassembly/assembly, always replace with a new one.

◆ **NOTE:** All work has to be performed in accordance with the relevant Maintenance Manual.

◆ **NOTE:** The illustrations in this document show the typical construction. They may not represent full detail or the exact shape of the parts which have the same or similar function.
Exploded views are **no technical** drawings and are for reference only. For specific detail, refer to the current documents of the respective engine type.

Approval of translation to best knowledge and judgement - in any case the original text in German language and the metric units (SI-system) are authoritative.

4) Documentation

4.1) List of the valid pages

Chapter	Page	Date	Chapter	Page	Date	Chapter	Page	Date	
	00-00-00	1	74-00-00	1	05 28 2010	78-00-00	3	11 03 2008	
	2	2		4					
	3	3		1					
	73-00-00	4	75-00-00	4	04 15 2008	79-00-00	2	04 15 2008	
		1		1			1		11 03 2008
		2		2			2		07 28 2008
	3	3	3	07 28 2008					
	4	4	4	07 28 2008					
	5	76-00-00	1	11 03 2008					
6	04 15 2008	2	11 03 2008						

4.2) Table of amendments

***Approval**
 The technical content of this document is approved
 under the authority of DOA Nr. EASA.21J.048.

Ser. No.	Section	Pages	Date of correction	Sign of acceptance	Date of accept. of resp. authority	Date of implementation	Sign/ Signature
0	00-00-00	all	04 15 2008	DOA*			
0	73-00-00	all	04 15 2008	DOA*			
0	75-00-00	all	04 15 2008	DOA*			
0	76-00-00	all	04 15 2008	DOA*			
0	78-00-00	all	04 15 2008	DOA*			
1	00-00-00	1,3	07 28 2008	DOA*			
1	73-00-00	5	07 28 2008	DOA*			
1	79-00-00	all	07 28 2008	DOA*			
2	00-00-00	1,3	11 03 2008	DOA*			
2	76-00-00	all	11 03 2008	DOA*			
2	79-00-00	1	11 03 2008	DOA*			
3	00-00-00	1,3	05 28 2010	DOA*			
3	74-00-00	all	05 28 2010	DOA*			
3	78-00-00	1	05 28 2010	DOA*			
	4	00-00-00	1, 3	11 24 2010	DOA*		
	4	00-00-00	4	11 24 2010	DOA*		

4.3) List of chapters

00-00-00	Introduction
73-00-00	Fuel system
74-00-00	Ignition system
75-00-00	Cooling system
76-00-00	Engine control
78-00-00	Exhaust system
79-00-00	Lubrication system

NOTES

SECTION 73-00-00

1) Introduction of a new flexible fuel line assy. part no. 874911 for ROTAX® 912 Series

1.1) General Information

(see fig. 1 and 2)

In the course of continuous development and for better assembly and maintenance a new flexible fuel line (part no. 874910) has been introduced.

Installation of this new fuel line requires the following modifications:

- mechanical machining at the intake manifold for the attachment of the cable clamp. At engine repair/general overhaul be aware that the fixation of the flexible fuel line needs an appropriate contact surface. If necessary replace the intake manifold or machine the contact surface according to the following instruction.

The new fuel line has been already installed on the following engines:

- 912 A as of S/N 4,410.713
- 912 F as of S/N 4,412.923
- 912 S as of S/N 4,923.384
- 912 UL^{*)} as of S/N 4,408.199
- 912 ULS^{*)} as of S/N 5,647.489
- 912 ULSFR^{*)} as of S/N 4,430.445

^{*)} optional installation possible

parts requirement:

Fig item no	New part no	Qty per engine	Description	Old part no	application
1	874911	1	fuel line assy.	874294	912
2	940872	2	banjo bolt M8x1x24	-	flexible fuel line
3	847795	2	spacer	-	flexible fuel line
4	950141	6	sealing ring A8x13	-	banjo bolt
5	651430	2	cable clamp 12/M8	-	flexible fuel line
6	940481	2	hex. screw M8X30	240276	carburetor socket
8	942671	2	hex. nut M8	-	cable clamp
9	866719	2	clamp	-	flexible fuel line
10	950143	3	gasket ring 8.2/13/1.4	-	banjo bolt/ clamp block

◆ NOTE: It is not mandatory to retrofit engines with the old stainless steel fuel line!

For a retrofit to a flexible fuel line system the following new parts are required:

parts requirement:

Fig item no	New part no	Qty per engine	Description	Old part no	application
	881980	1	flex. fuel line retrofit kit		retrofitting flexible fuel line
consisting of:					
	874911	1	fuel line assy.	874294	912
	940872	2	banjo bolt M8x1x24	-	flexible fuel line
	847795	2	spacer	-	flexible fuel line
	950141	6	sealing ring A 8x13	-	banjo bolt
	651430	2	cable clamp 12/M8	-	flexible fuel line
	940481	2	hex. screw M8X30	240276	carburetor socket
	942671	2	hex. nut M8	-	cable clamp
	866719	2	clamp	-	flexible fuel line
	950143	5	gasket ring 8.2/13/1.4	-	banjo bolt/ clamp block
	851325	1	clamp block - 912	-	clamp block
	230150	1	gasket ring 10x14	-	clamp block
	641733	1	hex. screw M10x1x8	-	clamp block
	840511	1	hex. screw M5x16	-	clamp block
	941785	1	banjo bolt kpl.	-	clamp block

d04317

APRIL 15th, 2008
Initial Issue

Copyright - ROTAX®

SI-912-020
SI-914-022

73-00-00

page 1 of 6

956312	1	ring hose nipple	-	return line
250311	2	washer 8.4	-	carburetor socket

- Install the flexible fuel line (1) with the double ring hose nipple (13) and sealing ring (10) on the clamp block (11). Tightening torque of banjo screw (14) 10 Nm (90 in. lb.) (see fig. 1).
- Install the ring hose nipple (15) with distance sleeve (3) and sealing ring (4) on the carburetors . Tightening torque of banjo screw (2) 10 Nm (90 in. lb.)
- ◆ **NOTE:** In case of a retrofit on configurations with steel fuel lines remove the screw connectors (12) and remove remaining sealant residues in a way that they do not get into the carburetor or the fuel system.
- For installation on an old style intake manifold perform the following: Remove the intake manifold and machine the nut/clamp contact area until the surface is parallel with the sealing surface of the carb socket. The thickness of the material must not be dressed down less than 10,5 mm (0.413 in.) and should be smooth and flat so that the nut/clamp assembly has an even contact surface (see fig. 2).
- Ensure proper support of the flexible fuel line. Install Hex. screw (6) and washer (7) with 15 Nm (133 in. lb.). Install the cable clamp (5) at the hex. screw (6) of the carburetor socket with the hex. nut (8). Tightening torque of hex. nut (8) 24 Nm (213 in. lb.)
- **CAUTION:** While tightening hex. nut (8), hold hex. screw (6) with a wrench to prevent it from loosening. Always fix the flexible fuel line at the compensation tube with clamps (9) in such a way that no wear is possible.

1.2) Illustration

the following drawings should convey additional information:

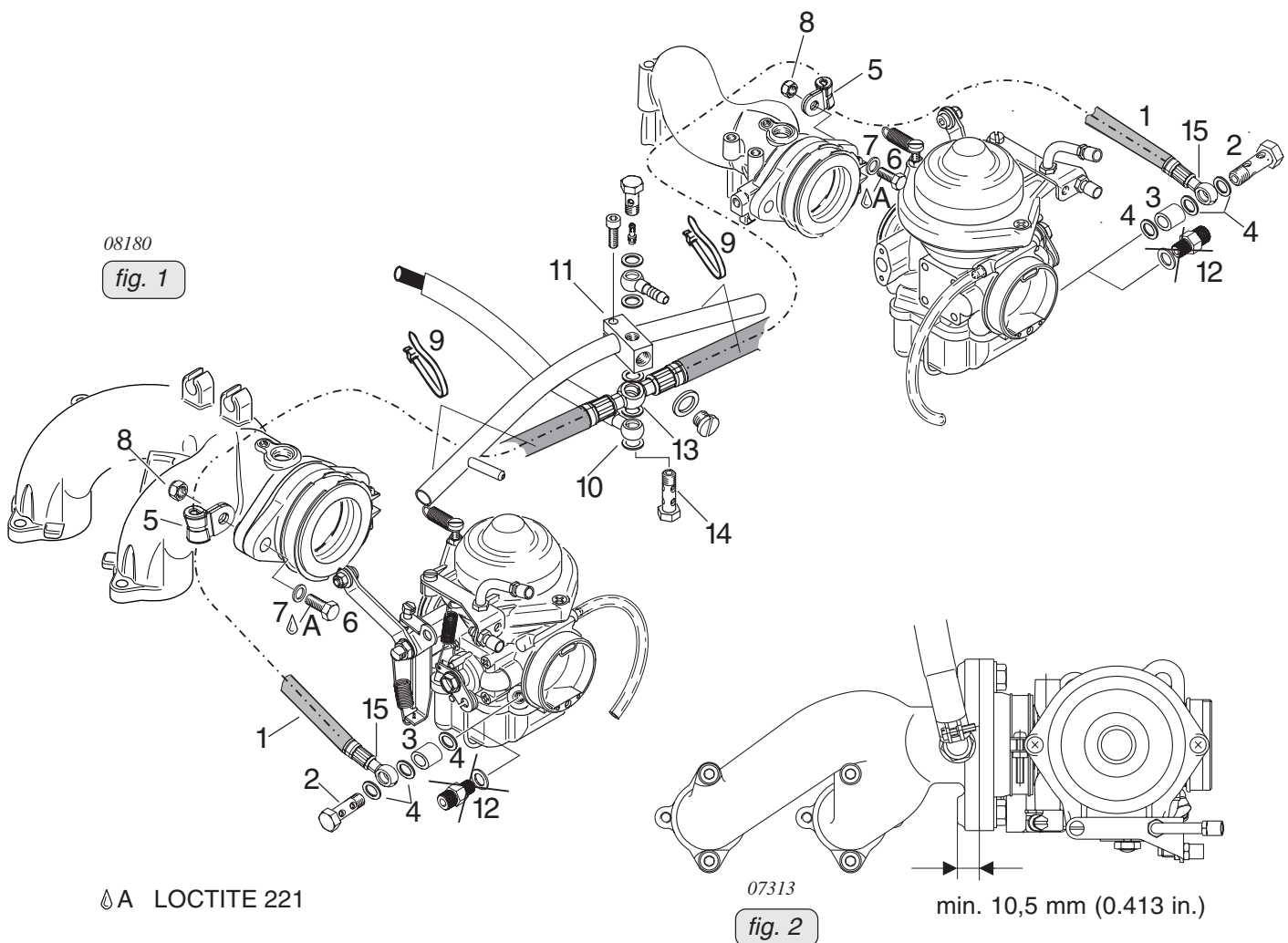

2) Introduction of a new gasket part no. 950226 for fuel pump ROTAX® 912 Series

2.1) General Information

(see fig.1)

In the course of continuous development a new gasket (1) (part no. 950226) has been introduced.

The new gasket has been already installed on the following engines:

- 912 A as of S/N 4,410.744
- 912 F as of S/N 4,412.929
- 912 S as of S/N 4,923.486
- 912 UL as of S/N 4,408.421
- 912 ULS as of S/N 5,648.605
- 912 ULSFR as of S/N 6,374.096

The new gasket has been already included in all fuel pumps delivered as spare part:

- fuel pump as of S/N 07.002119

parts requirement:

Fig item no	New part no	Qty per engine	Description	Old part no	application
1	950226	1	gasket	950225	fuel pump

The gasket is interchangeable.

2.2) Illustration

the following drawings should convey additional information:

- ◆ NOTE: On the sealing surfaces of the gearbox housing and the fuel pump no sealing compound has to be used.

⚠ B LOCTITE 243

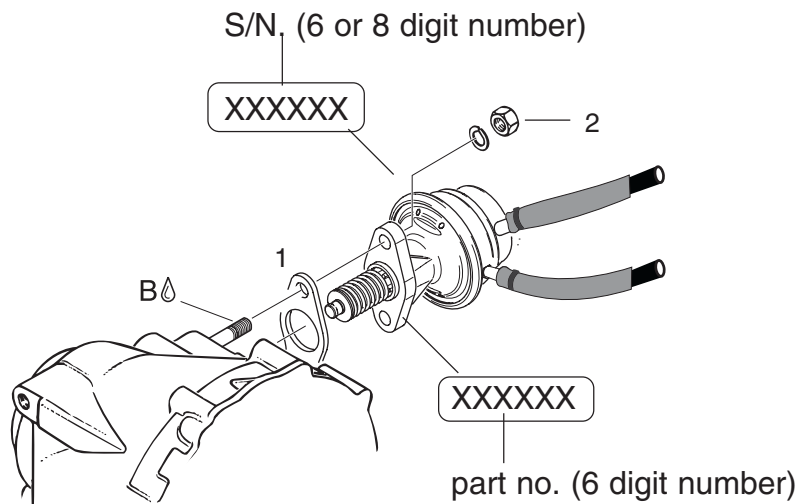

08353

fig. 1

3) Introduction of a new compensation tube part no. 924541 for ROTAX® 912/914 Serie

3.1) General Information

(see fig. 1 and 2)

In the course of continuous development a new compensation tube (1) (part no. 924541) has been introduced which the synchronization to make it easier, the tube must not removed.

In this connection the following modifications became necessary:

- position of connection fitting (3) on compensation tube remains approximate constant
- additional screw (2) part no. 940980 for connection fitting (3)
- new tube (4) part no. 956143 (5) part no. 956141

The new compensation tube has been already installed on the following engines:

- 912 A as of S/N 4,410.807
- 912 F as of S/N 4,412.949
- 912 S as of S/N 4,923.676
- 912 UL as of S/N 4,409.113
- 912 ULS as of S/N 5,650.899
- 914 F as of S/N 4,420.807
- 914 UL as of S/N 6,772.763

parts requirement:

Fig item no.	New part no.	Qty per engine	Description	Old part no.	application
	924541	1	compensation tube assy.	924540	intake manifold
	*)	1	tube 81 mm (3.2 in.)	-	compensation tube
		1	tube 66 mm (2.6 in.)	-	compensation tube

*) in a roll tube part no. 956141

- ◆ **NOTE:** In case of interchangeable it is not possible to exchange individual parts. The new compensation tube are only **together** interchangeable with the tube part no. 956141. In case of spare parts the relevant configurations must be observed.

Special tools:

Item no.	New part no.	Qty.	Description	Old part no.	Application
		1	hose clamping pliers ^{*)}		tube
		1	hose nipple	940557	intake manifold
		1	sealing ring 6.2/8.9/1	830890	intake manifold

^{*)} e.g. HAZET® **mean size** or equivalent. See fig. 2.

Pneumatic synchronization:

(see fig. 2)

The two carburetors are adjusted to equal flow rate (mechanical or pneumatical synchronisation) has to be performed in accordance with the relevant Maintenance Manual ROTAX® 912/914 and following changes must be observed:

additional variant (taking advantage of the new compensation tube):

1. Install the vacuum gauge.
2. Clamp the tube with hose clamping pliers (6). Observe the position! The tube (1) must not removed.
3. Unscrew the screw (7).
4. Install the hose nipple M6 (8) with the sealing ring (9).
5. After synchronization tightened the screw M6x6 (7) with LOCTITE 221.

Monitoring of the intake manifold pressure:

The monitoring of the intake manifold pressure has to be performed in accordance with the relevant Installation Manual ROTAX® 912/914 and following changes must be observed:

1. Unscrew the screw (2) from the connecting fitting (3) for indicating instrument.

- ◆ **NOTE:** If it is not possible to stabilize the intake manifold pressure, tighten the screw M3.5x6 (2) with LOCTITE 221. Install color markings on the screw.

3.2) Illustration

the following drawings should convey additional information:

compensation tube **part no. 924540**

08371

fig. 1

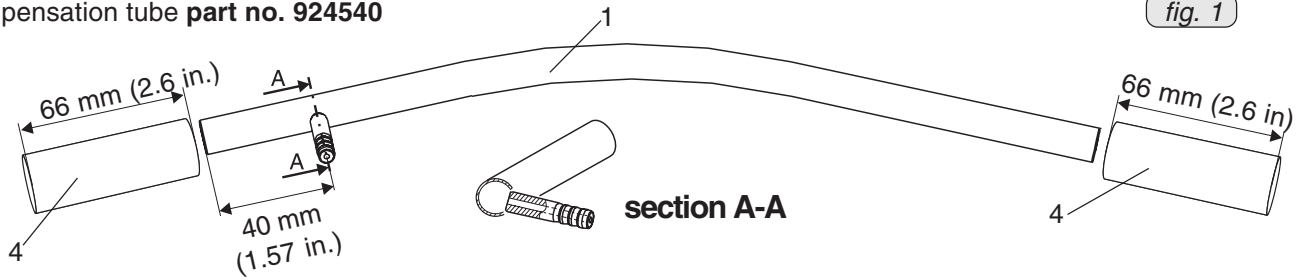

compensation tube **part no. 924541**

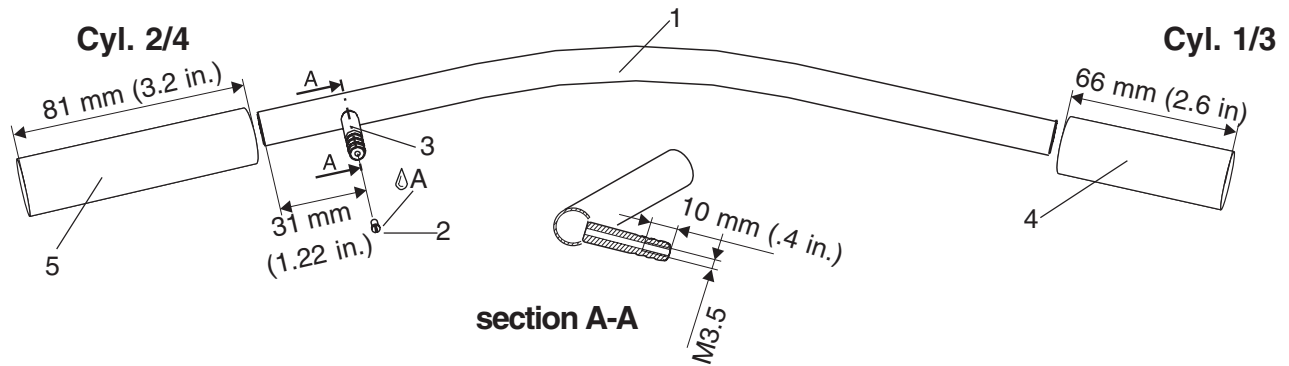

- 1 compensation tube
- 2 screw M3.5x6
- 3 connection fitting
- 4, 5 tube
- 6 hose clamp pliers
- 7 hex. screw M6x6
- 8 hose nipple M6
- 9 sealing ring 6.2/8.9/1

⊿ A LOCTITE 221

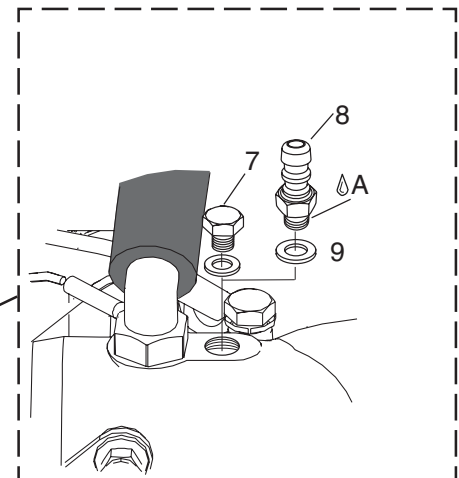
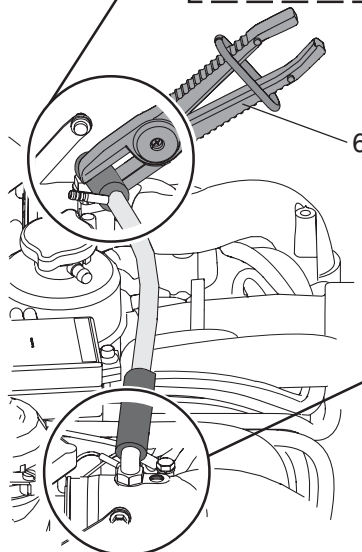
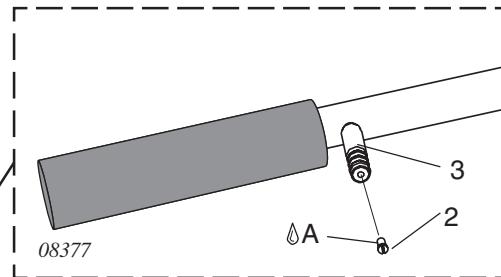

08449

fig. 2

NOTES

SECTION 74-00-00

1.) Introduction of a advanced start module (easy starting device for the electronic module)

1.1) General Information

(see fig. 1 and 2)

In the course of further development and standardization an electronic module for delayed start up ignition timing has been introduced. This module can be activated by a 12 V signal. Without this optional 12V activation the function works the same way as on the well-proven previous module.

In this context the following needs to be considered:

- 1 wire of each module circuit A and circuit B (6-pole) to start relay control signal wire (see position 26 in fig. 1) must be supplied by the aircraft manufacturer. Therefore the rubber plug of the pin terminal must be removed before!
- Time factor for delaying ignition timing at start until switching to advanced ignition: After starting the engine and as soon as the starter/relay is not powered anymore, the engine continues to further run for 3-8 seconds with delayed ignition.
- Do not connect the signal wire to the electric starter motor - as the circuit has not voltage protection.
- Do not power the advanced start terminal permanently with 12V. The delay timer function would be bypassed and charging speed might vary (depending on internal tolerances, trigger gap etc.).

The new electronic modules with a starting device have been already installed on the following engines:

- 912 S as of S/N 4,923.847
- 912 ULS as of S/N 6,775.360
- 912 ULSFR as of S/N 6,775.360

List of part no.:

Item no.	New part no.	Qty.	Description	Old part no.	Application
	966872	1	fly wheel hub	966871	ignition system
	881280	1	soft start port		ignition system
consisting of:					
	966727	2	SMD electronic module	966726	ignition system
	827800	1	disc A 5.5		ignition system
	240186	2	allen screw M5x25		ignition system
	945750	1	lock washer A5		ignition system
	260130	2	cable grommet		ignition system
	265275	2	faston connector		ignition system

◆ **NOTE:** Engines having an ignition system which is already equipped with the new 6-pin connectors can be upgraded with both the new module and the new fly wheel hub. Older engines (not having 6-pin connectors) can only be upgraded with the new fly wheel hub. As a retrofit would require considerable changes concerning the wiring.

Technical background information:

Differences between electronic module part no. 966726 and part no. 966727:

	<u>current 966726</u>	<u>new 966727</u>
	<u>fly wheel hub</u>	
ignition point at start	966871 current 4° Before T.D.C. 966872 new 3° After T.D.C.	4° Before T.D.C. 3° After T.D.C.
time delay for ignition at start:	none	3 - 8 sec.
Switching to advanced ignition:	from 650 to 1000 RPM depending on trigger gap	after the expiration of the time delay (3-8 sec.)
ignition timing in normal operation:	26° before T.D.C.	26° before T.D.C.

d04937

Installation:

- see latest Maintenance Manual (Heavy).

1.2) Illustration

the following drawings should convey additional information:

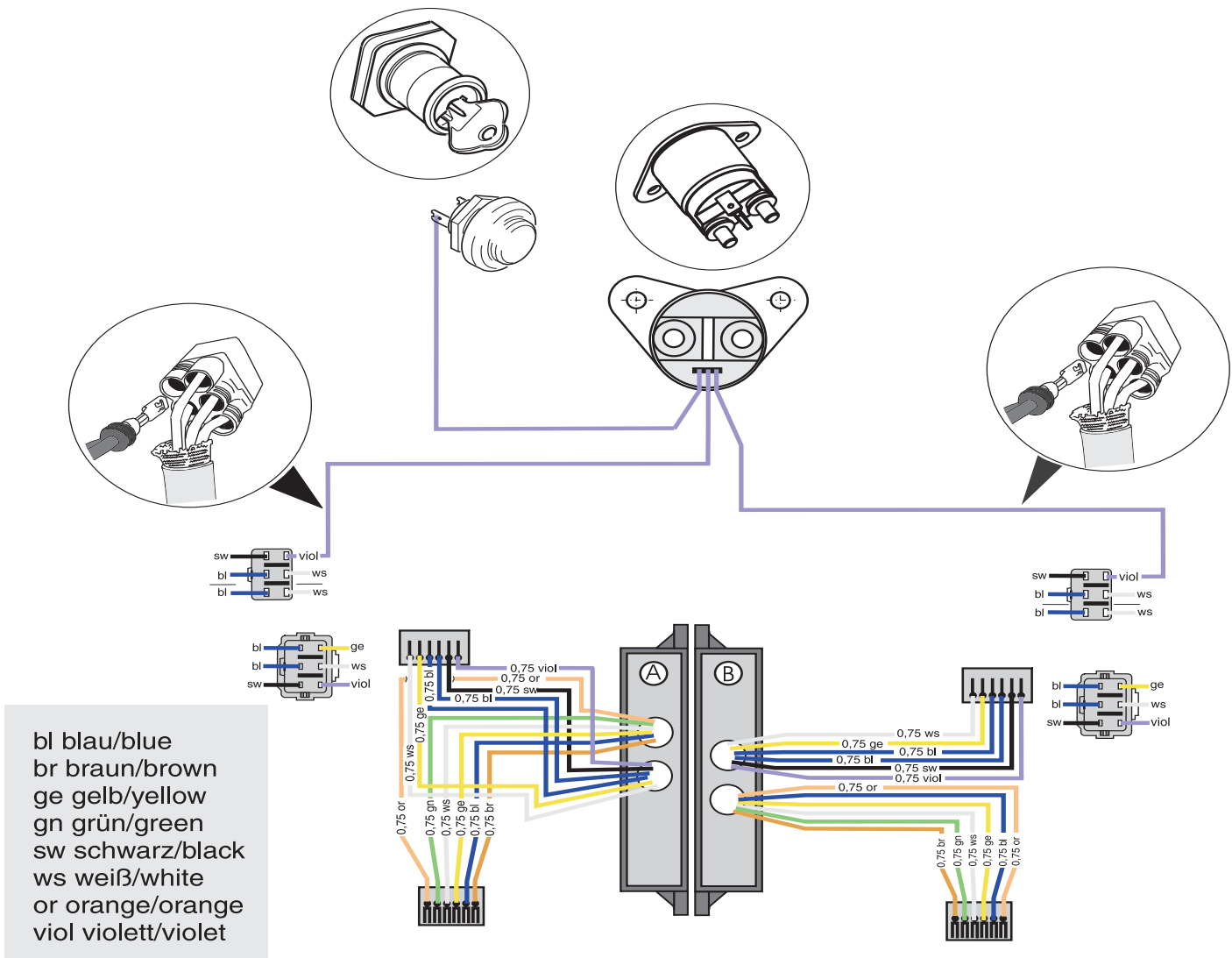

08684
fig. 1

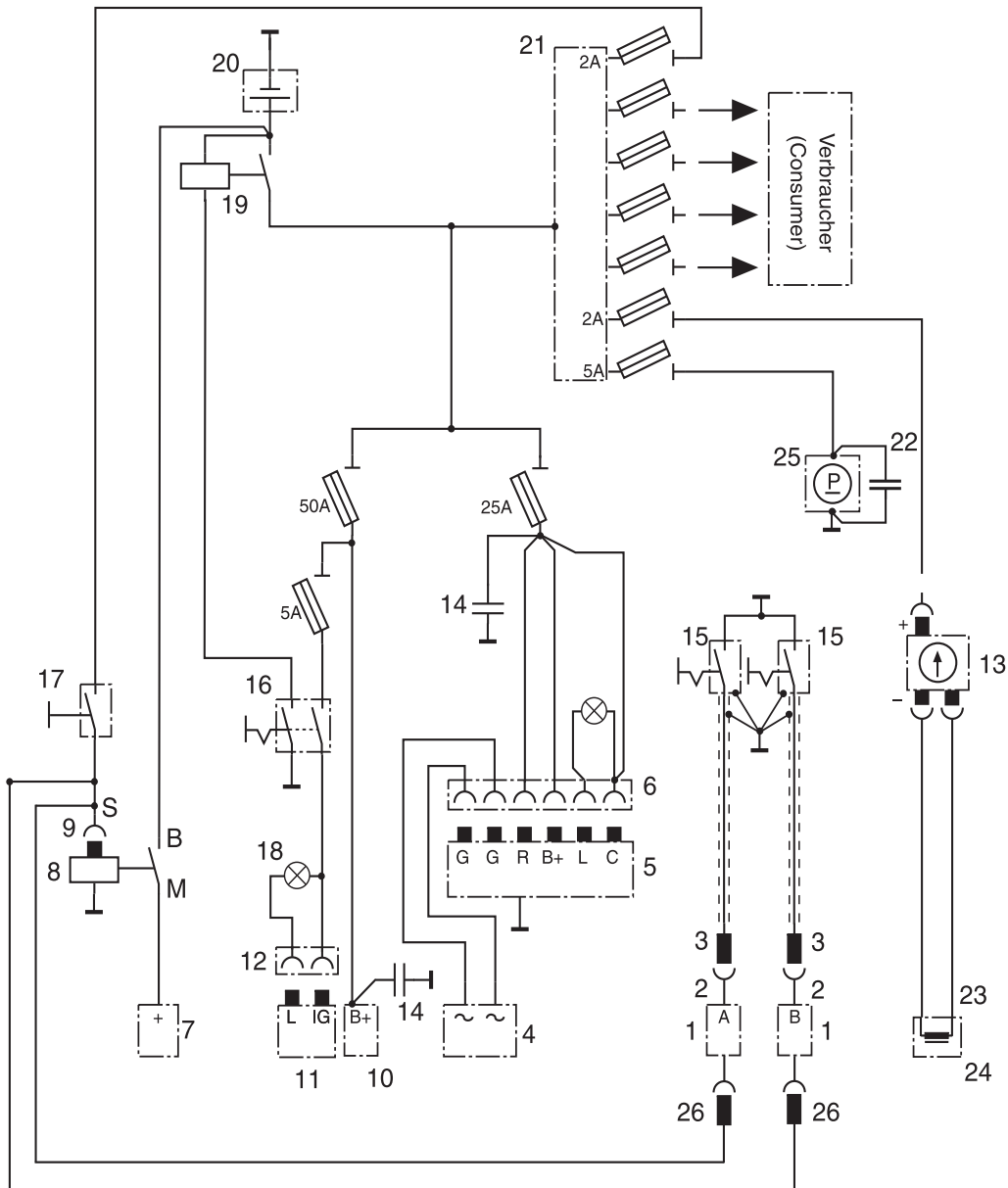

Wiring symbols to DIN 40712, 40713, 40716 and 40719

- | | | | |
|-------|--|----|--|
| B | battery | 15 | 2 ignition switches |
| M | engine | 16 | master switch |
| S | signal | 17 | starter button |
| 1 | 2 electronic modules (A and B) | 18 | control lamp |
| 2-3 | plug connection for ignition switch | 19 | battery relay |
| 4 | integrated generator | 20 | battery |
| 5-6 | external regulator - rectifier with plug connections | 21 | bus bar |
| 7 | electric starter | 22 | capacitor |
| 8-9 | starter relay with plug connection | 23 | plug connection for trigger coil assy. |
| 10-12 | external alternator with connections | 24 | trigger coil assy. (tachometer) |
| 13 | electric rev counter | 25 | electric fuel pump |
| 14 | capacitor | 26 | starting equipment at the electronic modules |

08673

08673

fig. 2

MAY 28th, 2010

SI-912-020 R3
SI-914-022 R3

74-00-00

page 3 von 4

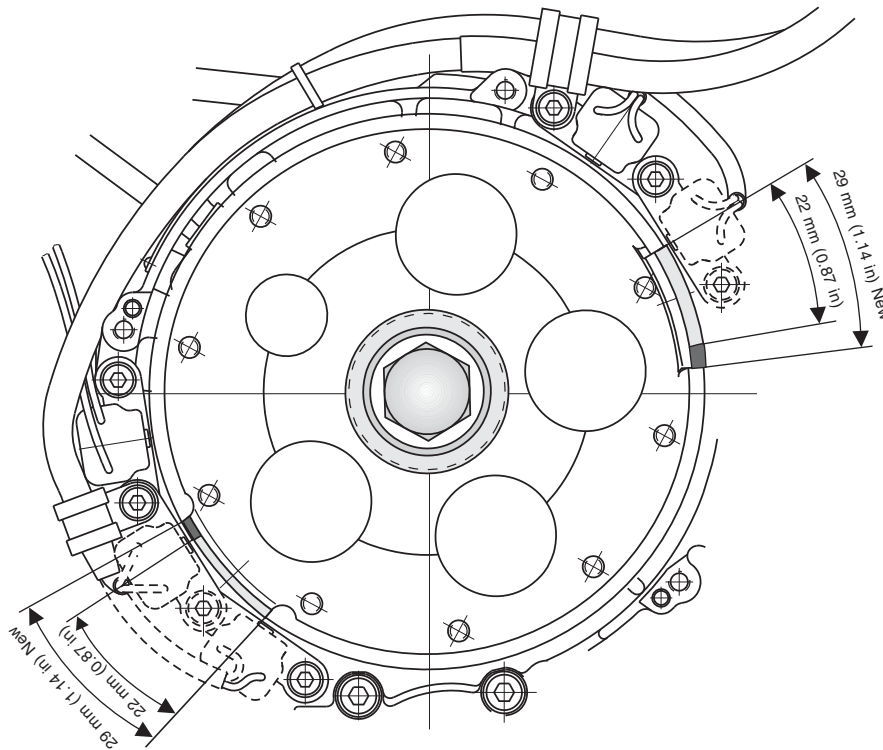

08685

fig. 3

2.) Introduction of an alternative spark plug part no. 897259 for ROTAX 914® Series

2.1) General Information

In the course of continuous development an alternative spark plug has been introduced.

2.2) Interchangeability of parts

- All parts are interchangeable.

parts requirement:

Fig item. no.	New part no.	Qty per engine	Description	Old part no.	application
	897259	8	spark plug DPR9EA-9	-	ignition system

◆ NOTE: Spark plug part no. 897257 with specification X27EPR-U9 is interchangeable. Any mixing of spark plug part no. 897259 and part no. 897257 should be avoided.

2.3) Removal and installation

- see latest Maintenance Manual (Line).

SECTION 75-00-00

1.) Introduction of a new expansion tank assy.

1.1) General Information

(see fig 1, 2 and 3)

In the course of further development and standardization the position of the expansion tank (1) has been optimized!

In this connection the following modifications became necessary:

- position of connection (2) to overflow bottle (from 0° to 30±3°)
- position of connection (3) to radiator (from 51° to 27±3°)
- angle of inlet socket (4) from cylinder 4 (34° inclined)
- length of inlet socket (5) from cylinder 3 (length increased by 13,4±3 mm)
- length of coolant hose (6) from cylinder 1 (length increased from 270 mm to 285 mm)
- length of coolant hose (7) from cylinder 4 (shortened from 100 mm to 85 mm)
- new spring type hose clamps (8) to attach the coolant hoses (expansion tank and water pump)

The new expansion tank and the new type of hose clamps have been already installed on the following engines:

- 912 A as of S/N 4,410.419
- 912 F as of S/N 4,412.808
- 912 S as of S/N 4,922.606
- 912 UL as of S/N 4,404.020
- 912 ULS as of S/N 4,426.395
- 912 ULSFR as of S/N 4,429.589
- 914 F as of S/N 4,420.235
- 914 UL as of S/N 4,417.949

List of part no.:

Item no.	New part no.	Qty.	Description	Old part no.	Application
1	922665	1	expansion tank assy.	922398	cooling system
8	851640	16	spring type clamp	251875	cooling system
6)	1	coolant hose 285 mm	922542	cylinder 1
7)	1	coolant hose 85 mm	922541	cylinder 4

) water hose in meters part no. 922250.

◆ NOTE: Engines equipped with the old expansion tank, old hose clamps and coolant hoses of old length do not have to be retro fitted with the new equipment!

At engine repair/general overhaul be aware that because of the small distance of the tubes (between cylinder 1 and 3) the spring type hose clamps can not be fitted on the expansion tank part no. 922398.

Due to the different inlet and outlet positions on the expansion tanks, hoses of different length are required. Always verify correct hose length and slip-on length.

Special tools:

Item no.	New part no.	Qty.	Description	Old part no.	Application
	877840	1	spring clamp pliers ⁾		spring type clamp

) e.g. HAZET®, BERNER® or equivalent. See fig. 3.

Assembly:

- Inspect the rubber plate (10).

◆ NOTE: Wear of up to 1 mm from original thickness can be tolerated!

d02674

- Install the coolant hose (6) 285 mm to cylinder 1 and the new coolant hose (7) 85 mm to cylinder 4. For attaching all the coolant hoses from expansion tank, water pump, cylinders, use the new spring type clamps.

■ **CAUTION:** Take care of appropriate slip-on length of the coolant hoses on the corresponding connection socket. Verify tight fit of clamps and hoses and check for leakage. Always fit the clamps such that they can not wear on any component and use a suitable tool (see fig. 3) for fitting them.

1.2) Illustration

the following drawings should convey additional information:

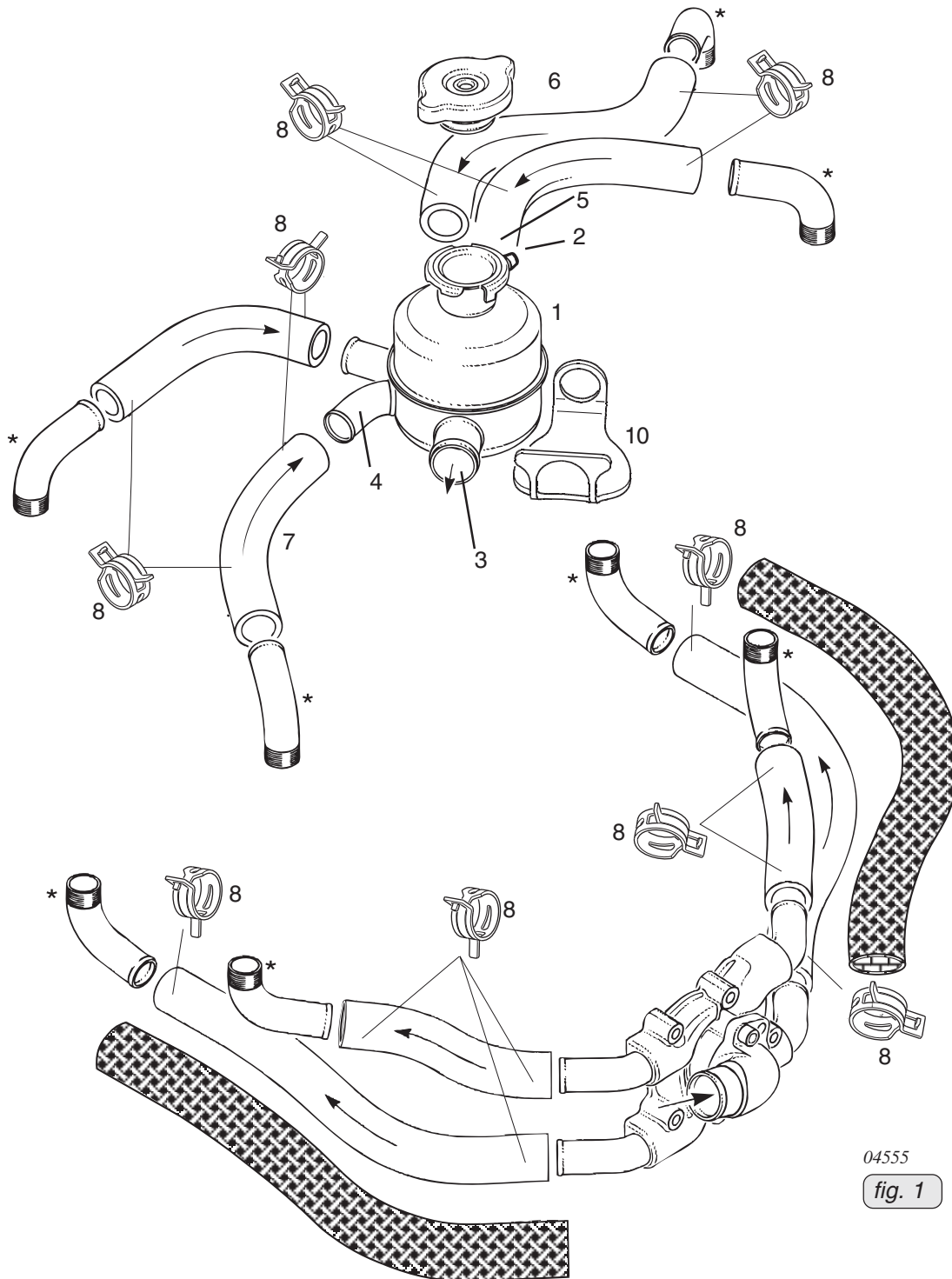

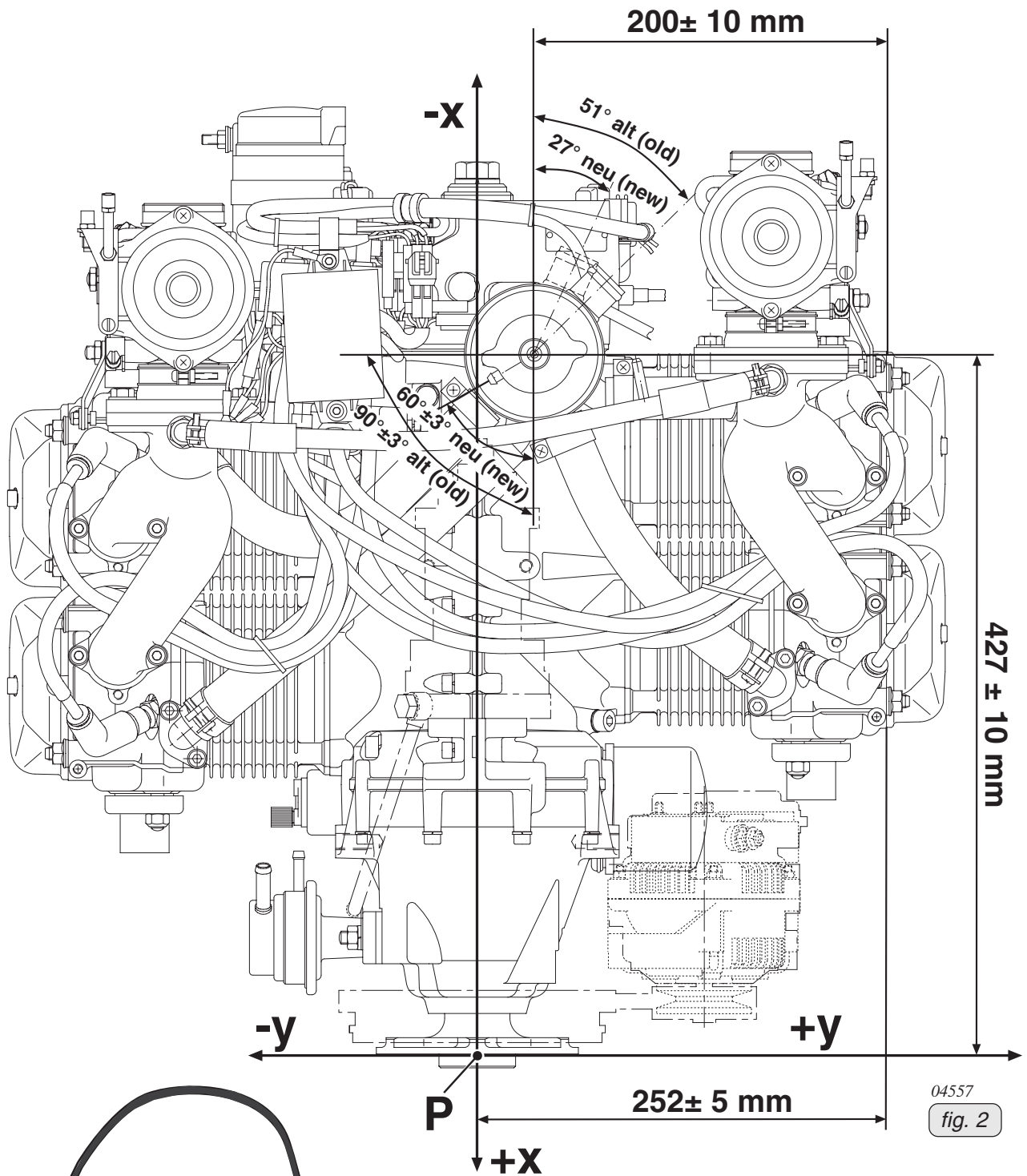

04557

fig. 2

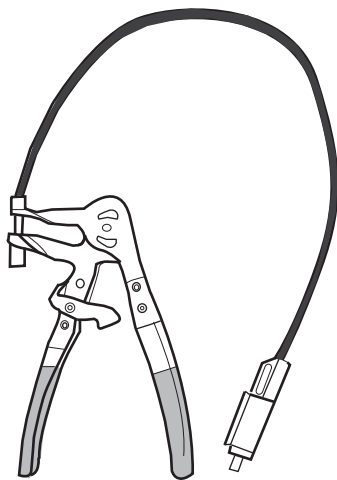

08380

fig. 3

NOTES

SECTION 76-00-00

1.) Introduction of a new 3-way solenoid valve part no. 874313 for ROTAX® 914 Series

1.1) General Information

Owing to change of supplier from the new 3-way solenoid valve (part no. 874313) an adapted wiring harness and an airbox part no. 667574 have been introduced.

The new 3-way solenoid valve has been already installed on the following engines:

- 914 F as of S/N 4,420.710
- 914 UL as of S/N 4,419.744

1.1.1) Interchangeability of parts

The current 3-way solenoid valve part no. 874310 is available anymore only in limited number of items. Particularly for repair, and exchange purposes the retrofit kit part no. 881040 is provided.

◆ NOTE: If replacement of wiring harness part no. 966490 is necessary the 3-way solenoid valve must be also replaced.

Accessories and attachment of the 3-way solenoid valve could differ because of the possible variants of the airbox.

1.1.2) Disassembly and assembly

See the latest Maintenance Manual 914.

2.) Introduction of a new pressure sensor part no. 274051 for ROTAX® 914 Series

2.1) General Information

Due to the termination of production of the ambient pressure sensor (part no. 966507) a new ambient pressure sensor part no. 274051 has been introduced. The new ambient pressure sensor is of different size and also has a different connector. The connection for the wiring harness had to be changed.

Pressure sensor and wiring harness have already been installed on the following engines:

- 914 F as of S/N 4,420.863
- 914 UL as of S/N 6,773.116

2.1.1) Interchangeability of parts

The current pressure sensor part no. 966507 is of limited availability.

Fig No.	New p/n	Qty/ engine	Description	Old part no.	Application
1	274051	1	pressure sensor	966507	ambient pressure
3	666012	1	adapter cable	-	wiring harness
4	924990	1	bracket	-	pressure sensor

◆ NOTE: If replacement of wiring harness part no. 966493 is necessary the pressure sensor and the bracket must be also replaced.

2.1.2) Disassembly and/ or new assembly

See Fig. 1 and 2.

1. Disconnect the pressure sensor (2) from the wiring harness.
2. Connect adapter cable (3) to wiring harness and to the new pressure sensor (1).
3. Install bracket (4) onto pressure sensor.

■ CAUTION: Route all wiring as such that there will be no sharp bends or chafing.
4. Position adapter cable and secure with cable binders (5).

2.2) Summary

The instructions have to be conducted accordingly.

2.3) Illustration

the following drawings should convey additional information:

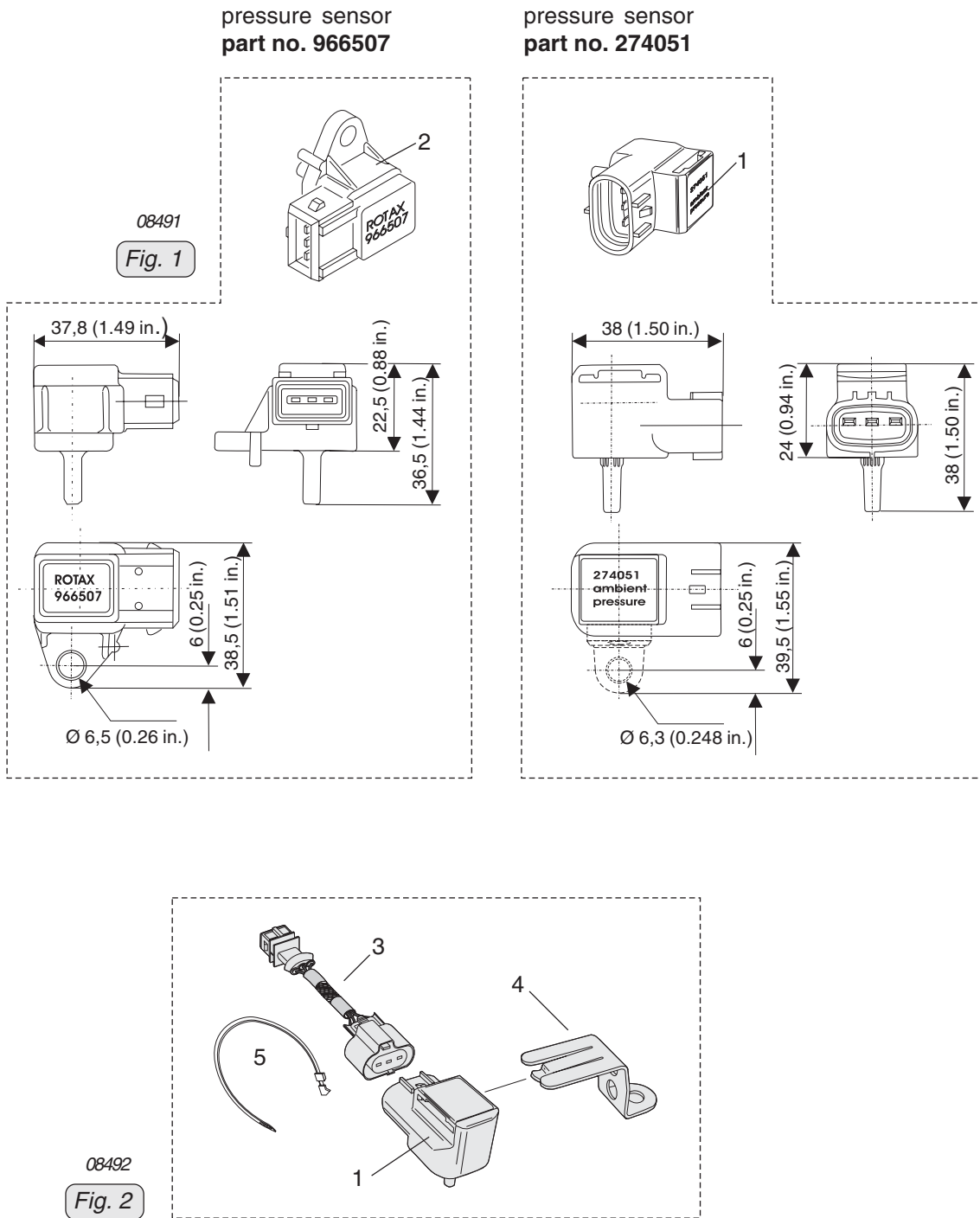

3.) Introduction of a new FLYdat part no. 886858 for ROTAX® 912/914 Series

3.1) General Information

In the course of continuous development a new FLYdat part no. 886858 has been introduced, which simplifies data selections, because the new FLYdat operates via USB (own power supply).

3.1.1) Interchangeability of parts

At replacement take care of the following:

Take care of the respective oil pressure sensor! See also 79-00-00 sec. 1.3).

- ◆ NOTES: For more information, please contact an authorized distributor or Service Center for ROTAX® aircraft engines.

part no. overview:

The following tables offer additional information about characteristics of the different versions.

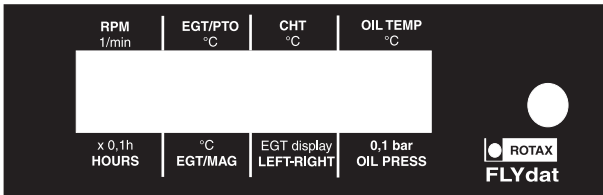
Model 1993	FLYdat part no. 886855 German, 886856 English
Characteristics	<ul style="list-style-type: none"> - 2 different front panels (German and English) - Service messages can only be resetted by a ROTAX® authorized distributor - External warning lamp - Jack plug
Software	<ul style="list-style-type: none"> - Read out of data via RDAT part no. 886980 (no direct software for the PC) or - FLYdat monitoring device part no. 891315 (Windows system software)
	

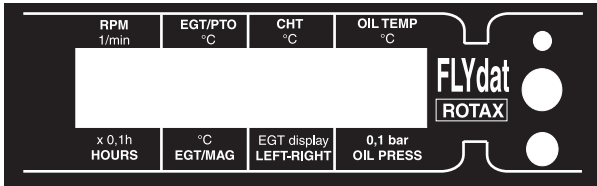
Model 2004	FLYdat part no. 886857
Characteristics	<ul style="list-style-type: none"> - 1 version (English) - consistent design of the front panel - Button to reset the service messages - Warning lamp with display in case of exceeding maximum permissible value - Jack plug
Software	<ul style="list-style-type: none"> - Configuration of the FLYdat via PC - RS232 interface to the PC - Read out via PC (voltage of min. 10V necessary) - Windows system software - Firmware Update possible
	

Model 2008	FLYdat part no. 886858
Characteristics	<ul style="list-style-type: none"> - 1 version (English) - Button to reset the service messages - Warning lamp with display in case of exceeding maximum threshold - USB connection
Software	<ul style="list-style-type: none"> - USB Type A-interface to the PC (read out and configuration with Standard USB connecting cable possible) - Power supply via USB connection - Windows system software - Firmware update possible

SECTION 78-00-00

1) Introduction of new exhaust bends an exhaust manifold on ROTAX® 914

1.1) General Information

(see fig. 1 to 2)

Owing to continuous further development, the exhaust bends were slightly re-worked. The couplings were optimized for their position.

- Position of the EGT connections (6) to the exhaust bends for cylinders 3 and 4 were routed such that installation of the new drip trays is possible.

The new exhaust bends and the new exhaust manifold have already been built into all of the following engines:

- 914 F as of S/N 4,420.364
- 914 UL as of S/N 4,418.248

parts requirement:

Fig item no	New part no	Qty per engine	Description	Old part no	application
1	979425	1	exhaust bend assy cyl. 1	979420/421/422	ROTAX® 914
2	979435	1	exhaust bend assy cyl. 2	979430/431/432	ROTAX® 914
3	979445	1	exhaust bend assy cyl. 3	979440/441/442	ROTAX® 914
4	979455	1	exhaust bend assy cyl. 4	979450/451/452	ROTAX® 914
5	979413	1	exhaust manifold	979411	ROTAX® 914

◆ NOTE: If replacement of any single old part number is necessary, you must replace it with the same old part number. If the old part number is not available, the **entire** assembly including all 4 pipes and manifold must be replaced with new part numbers. New style pipes and manifold are not interchangeable with old style.

1.2) Illustration

the following drawings should convey additional information:

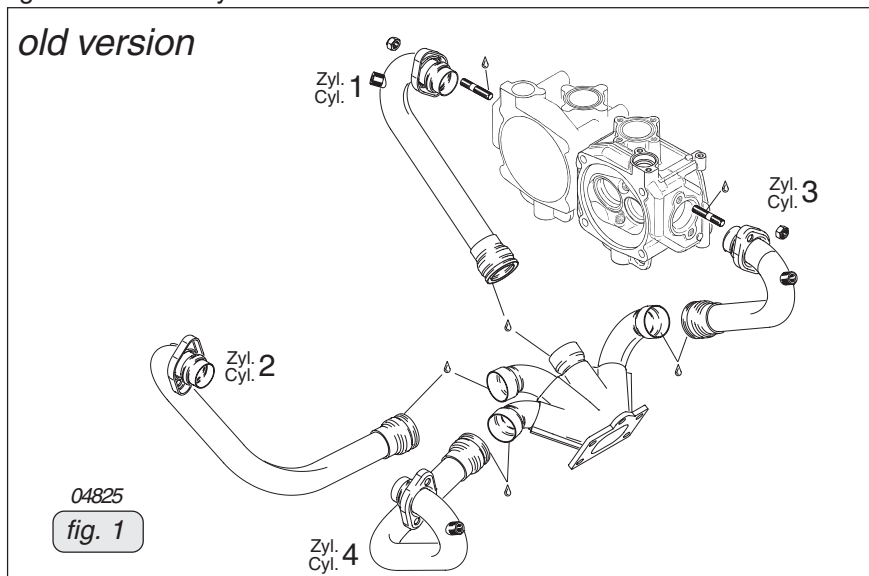

new Version

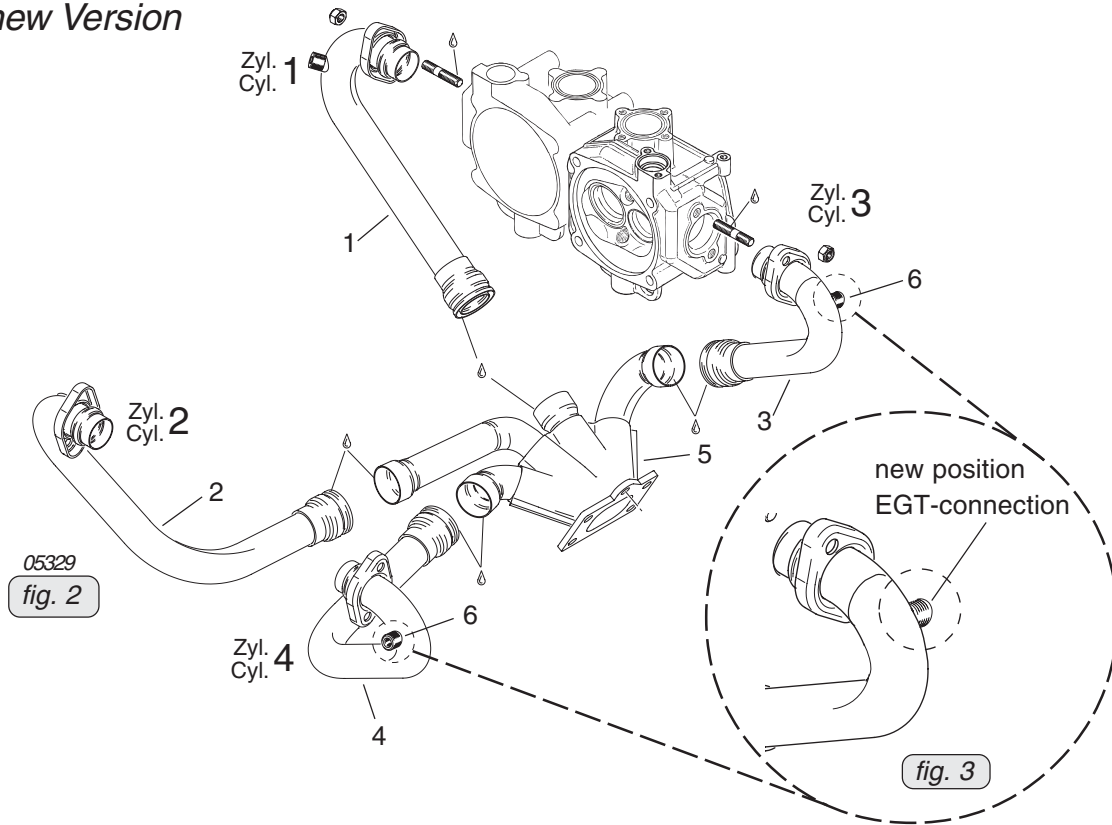

SECTION 79-00-00

1.) Introduction of a new oil pressure sensor for ROTAX® 912/914 Series

1.1) new oil pressure sensor

(see fig. 1, 2 and 3)

In the course of further development and standardization a new oil pressure sensor part no. 956413 has been introduced.

The new oil pressure sensor has been already installed on the following engines:

- 912 A as of engine S/N 4,410.817
- 912 F as of engine S/N 4,412.955
- 912 S as of engine S/N 4,923.748
- 912 UL as of engine S/N 4,409.340
- 912 ULS as of engine S/N 5,651.797
- 914 F as of engine S/N 4,420.825
- 914 UL as of engine S/N 6,773.026

- location: oil pump housing

- wiring connection for instrument:

The sensor cable is approx. 3 m long and has 3 leads. The **Black** lead is not to be connected and has no function. The **Red** lead from the sensor has to be connected to the positive bus via a fuse or circuit breaker. The **White** lead (output signal) has to be connected directly to the instrument. See also the relevant instructions of the instrument supplier/aircraft manufacturer for correct connection and wiring.

◆ **NOTE:** The sensor cable can be modified in its length according to the installation situation, e.g. shortened or extended. For extension an appropriate, commercially available cable can be used. A resistance cable or similar is not necessary.

- wire gauge: stranded wire, 0,5 mm² (AWG 20)

- cable length: 3 m (118 in.)

- operating temperature range:

min.: - 40 °C (-40 °F)

max.: + 125 °C (+ 257 °F)

- grounding: via engine block/airframe ground

- output signal:

In contrary to the oil pressure sensor offered up to now, which was providing the signal on the basis of a sensor resistance variation, the new oil pressure sensor operates on basis of a current variation. This has to be taken into account for the selection of the appropriate cockpit instrument.

■ **CAUTION:** The graph current over pressure has been determined, and is effective at the following conditions only (see fig. 1).

ambient temperature: 20 °C (68 °F)

tolerance: ± 3%

- tightening torque: 15 Nm (98 in.lb) and LOCTITE 243

1.2) Resistance type instruments

- As the instruments need a separate power supply and a different design for the electrical oil pressure sensor, the resistance type instrument (type VDO), which was supplied by BRP-Rotax up to now, is not suitable anymore. Suitable instruments are offered by various instrument manufacturers (e.g. ROAD or Aviasport)

▲ **WARNING:** Certification to the latest requirements such as FAR of EASA has to be conducted by the aircraft manufacturer.

1.3) ROTAX® Flydat

1.3.1) ROTAX® Flydat part no. 886858

- The ROTAX® Flydat part no. 886858 is already prepared for the electronic oil pressure sensor concerning its hardware and software.

d04397

1.3.2) ROTAX[®] Flydat part no. 886857

- For the ROTAX[®] Flydat part no. 886857 a retrofit kit for the electronic oil pressure sensor is offered.

◆ **NOTE:** For more information, please contact an authorized distributor or Service Center for ROTAX[®] aircraft engines.

1.3.3) old models of ROTAX[®] Flydat

- For older ROTAX[®] Flydat models as e.g. part no. 886856/886855 a retrofit is not possible.

1.4) Illustration

the following drawings should convey additional information:

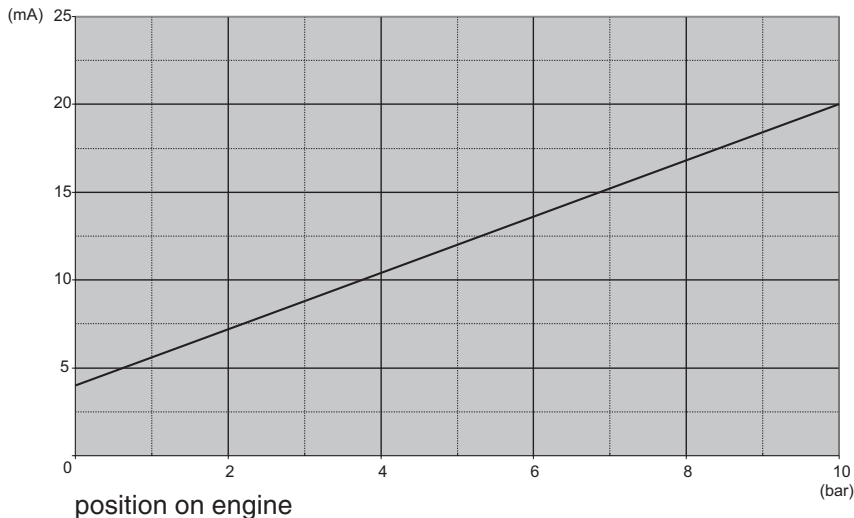

08442

fig. 1

oil pressure sensor **part no. 956415**

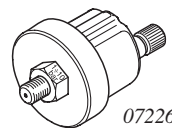

07226

oil pressure sensor **part no. 956413**

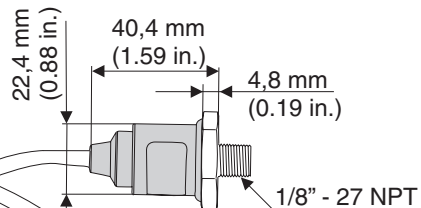

08370

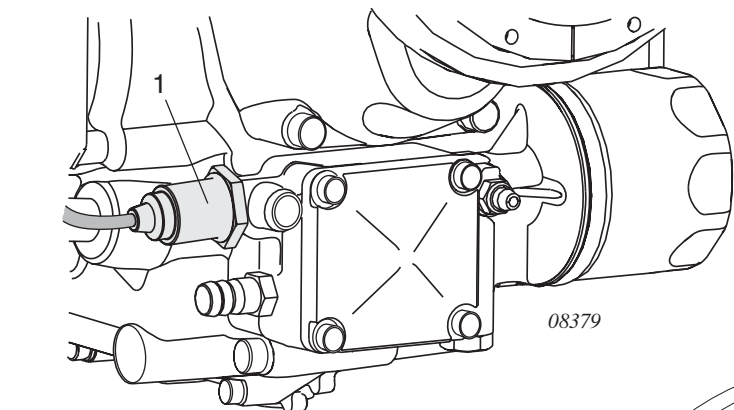

08379

1 oil pressure sensor

L~3 m
l~ 118 in.

fig. 2

L~150 mm
l~ 6 in.

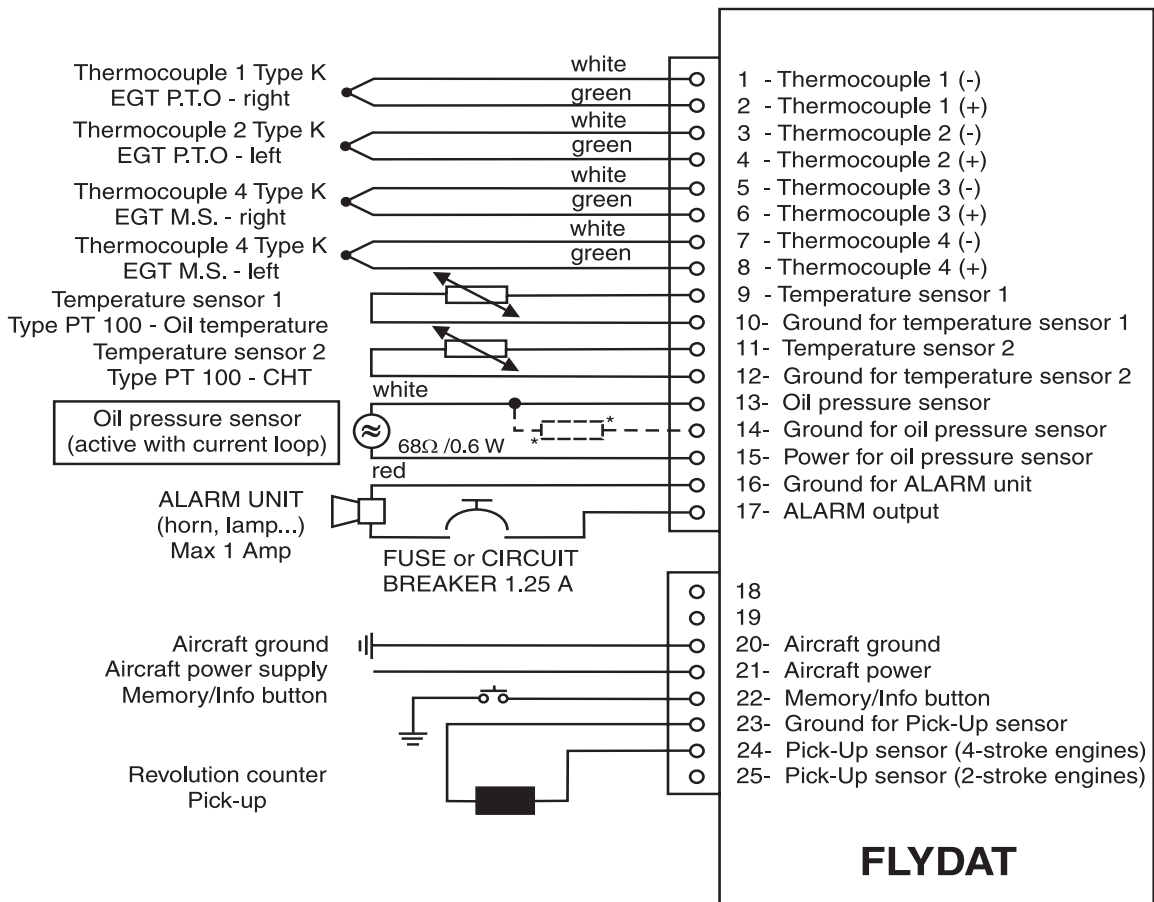

* resistor is part of the retrofit kit for Flydat part no. 886857. See also 1.3.2.

08446

fig. 3

NOTES